



# SleeveBOT®

THE BEST ROBOT FOR AUTOMATIC  
SLEEVE CHANGEOVER

  
**Uteco**  
JOIN THE FLEX-CONVERTING

SleeveBOT®

---

The **Best Robot** for **Automatic Sleeve** Changeover, **EVER!**



# SleeveBOT®

## Front and back **Adaptable Gripper**.



Arm for  
**Automatic**  
Positioning



The front and the back  
are equipped with  
**Adaptable Grippers** that  
go Inside the Sleeves

Innovative  
**Patented**  
Gripper



# SleeveBOT® - Value Proposition Overview

---

**SLEEVE**BOT®

1 The Most **Productive**

2 The Most **Cost-Effective System**

3 The **Safest & Most Robust**

# 1. The Most Productive Sleeve Changeover

The **Fastest Sleeve Changeover** in the market.

**Press Minimized Downtime:** add up to **6.9 M€** of Extra Production over Machine Lifetime (\*)

The Fastest VS Semi-Automatic platforms in the market

The Fastest VS Robotic solutions in the market

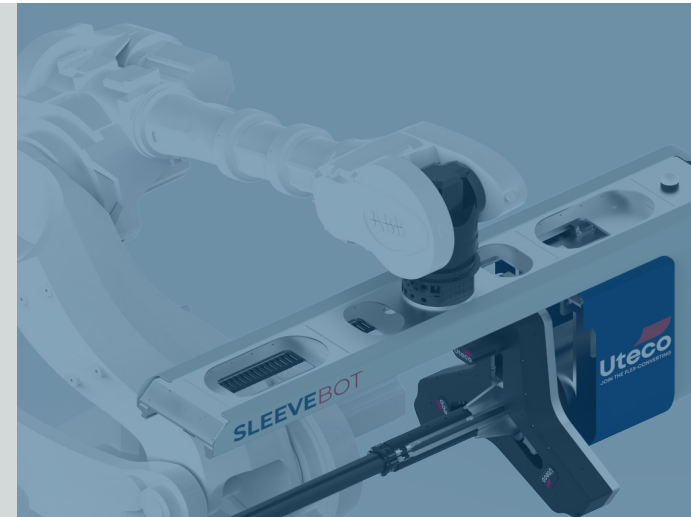

**Ensure Lowest Machine  
Downtime during  
Changeover**

(\*) Vs Semi-automatic Solutions in the market and assuming



## 2. The Most Cost-Effective System for Sleeve Changeover

---

Our Innovative **Patented Gripper**.

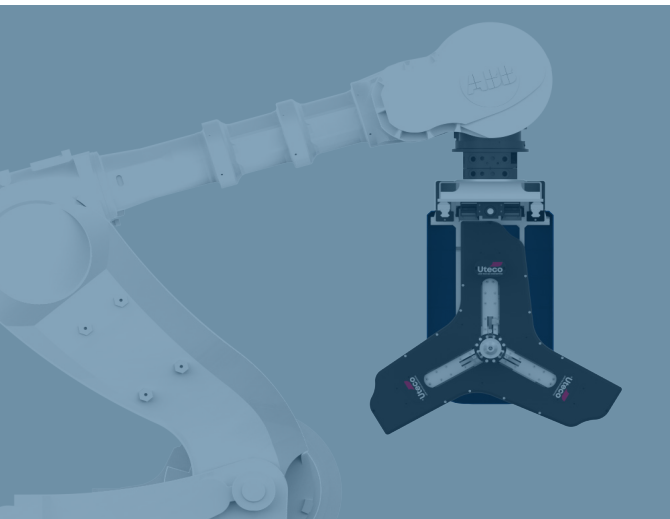

No special mandrels or special sleeves needed

Single Gripper for all the Sleeves' Changes

Adaptable Gripper to any Sleeve's Size

Change Sleeve Only keeping the carrier and axis on-board



The Most Efficient  
Sleeve Changeover, Ever!

**PURCHASE AND MAINTAIN A SINGLE GRIPPER  
WHILE USING EXISTING CUSTOMERS' SLEEVES**

### 3. The Safest and Most Robust

---

The Best Robot for **Operator Ergonomics** and **Safety**.

**Robotics Automation Technology**

guarantees process quality, robustness and repeatability regardless of operators' skills

**Safe Working Environment**

since operator does not handle heavy sleeves on elevated platform from high above ground position



**100% PROCESS  
ACCURACY AND  
REPEATABILITY**



**FULL OPERATORS  
SAFETY**



**Fully Automated  
Sleeve Changeover  
in Total Safety**



# SleeveBOT® - Key Features Overview

---

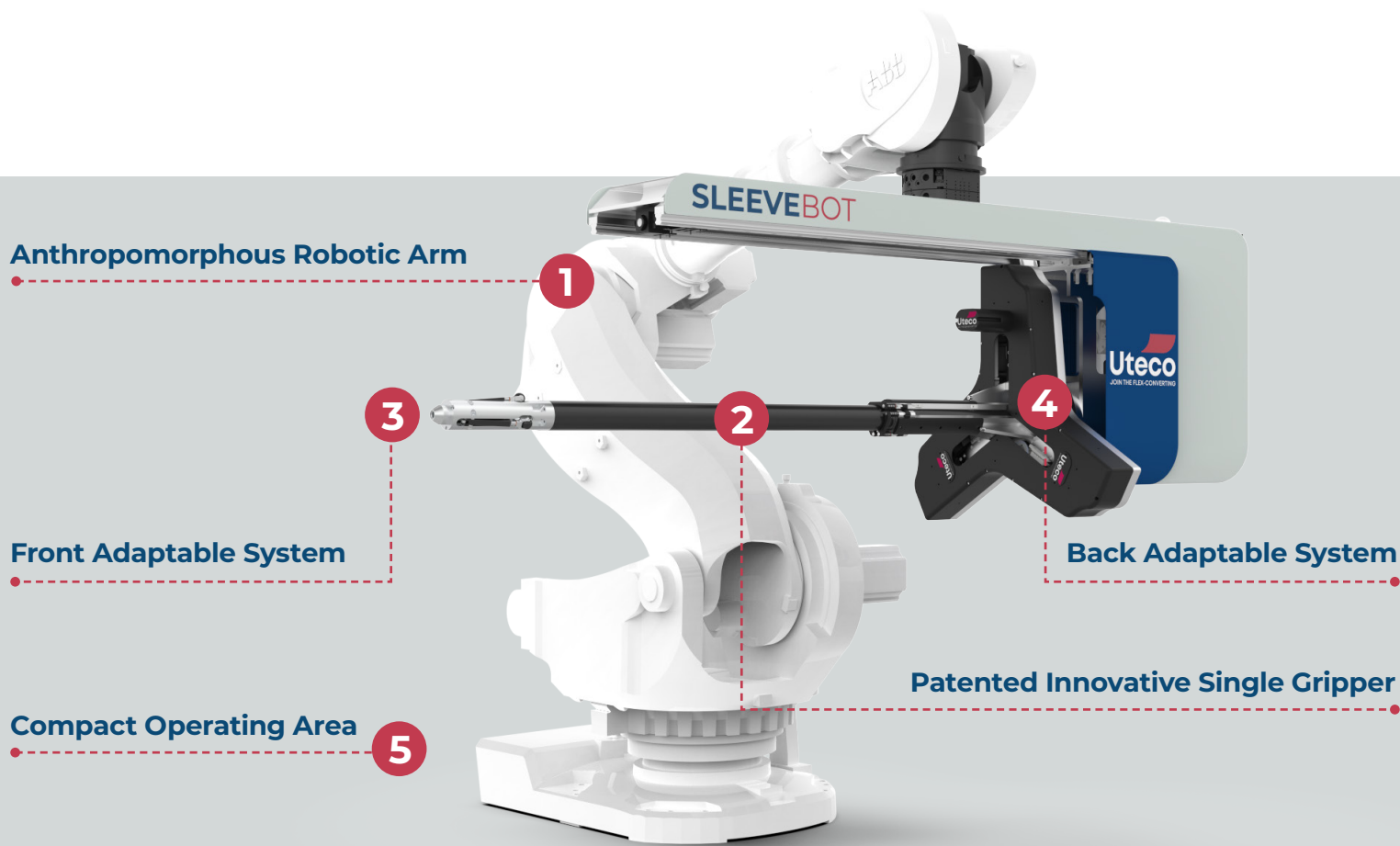



# 1. Our Anthropomorphous Robotic Arm

---

## Fully Automatic Sleeve **Changeover**.

Our New **Robotic Arm** has been designed to perform very **fast movements** using the latest available robotic technologies available in the market

**Repeatable Performance** over Time

**No operator intervention** needed during heavy sleeve changeover operations, re-allocation his activity to more value-added tasks for new job setup (e.g. recipes setup, colors setup,...)



**SleeveBOT® is our New Anthropomorphous Robotic Arm**



## 2. Our Innovative Patented Gripper

---

### Our Innovative Fast **Patented Gripper**.



**Adaptable and  
Single Gripper**

Our **New Innovative Gripper** is unique in the market since it does never need to be substituted when changing sleeves formats. This means purchasing and maintaining a Single Gripper

- **Fast Gripping Sleeve Changeover: < 10 min (\*)**
- **Press Minimized Downtime:** add up to **6.9 M€ of Extra Production** over Machine Lifetime Vs non robotic Solutions

(\*) Considering 8 Color Flexo Press - Considering the Change of 3 Sleeve Aniloxes + 8 sleeve Clichés

### 3. Gripper Front Adaptable System

---

The Front of the Gripper Adapts to any **Sleeve Internal Size**.

The **frontal part adapts** to any size of the sleeves in use. This means never stopping during job changeover to change the gripper (this is necessary with other main solutions available in the market)

- **Fit Any Sleeves' Size** already in use by the customer
- **No need** to purchase and maintain **special sleeves** (with flanges)
- **Change only the sleeves** while keeping carrier and axis on board



Use your  
Existing Sleeves



## 4. Gripper Back Adaptable System

---

The Back of the Gripper Adapts to any **Sleeve Internal Size**.

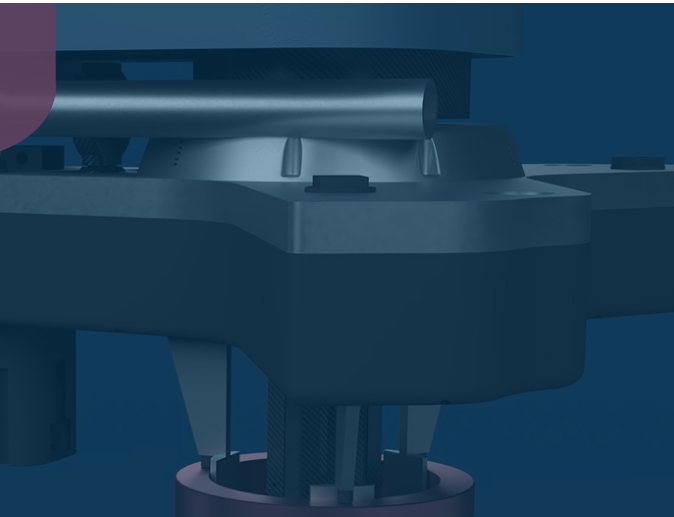

Unique gripper that adapts to the size of any sleeve

- The back part adapts to any size of the sleeves in use. This back part of the gripper pushes the sleeve into the printing units
- **Fit Any Sleeves' Size** already in use by the customer
- **No need** to purchase and maintain **special sleeves** (with flanges)
- **Change only the sleeves** while keeping carrier and axis on board

## 5. Compact Operating Area

---

**Load and Unload Sleeve** only into the Trolleys.  
No need for Disassembling Areas.

Our **New Innovative Gripper** allows to load and unload **only the sleeves, leaving carrier and axis on-board** of the flexo CI press

- **No need for Operating Areas** around the machine to disassemble Sleeve, Carrier and Mandrels – with dedicated manpower
- **No need** to have extra spare carriers, sleeve and mandrels



## Our Company

---

Printing and converting: all round **high tech innovation.**



■ We provide innovative and flexible solutions from a wide range of flexographic, gravure, digital printing, and laminating and coating machines, and a corollary of comprehensive training and support services.

■ We develop special and customized configurations of high technological value, with an ongoing commitment to research and innovation, organizational flexibility, engineering capabilities for final solutions, optimization of production processes, and a fast and efficient worldwide service network.

## Our Customer Service

---

Our Customer Service has **everything you need.**

Our expert **Customer Service teams** are **available 24/7** to respond quickly and effectively to requests for maintenance, repairs and operational renovations to machinery and systems, **both on-site and remotely (My Portal).**

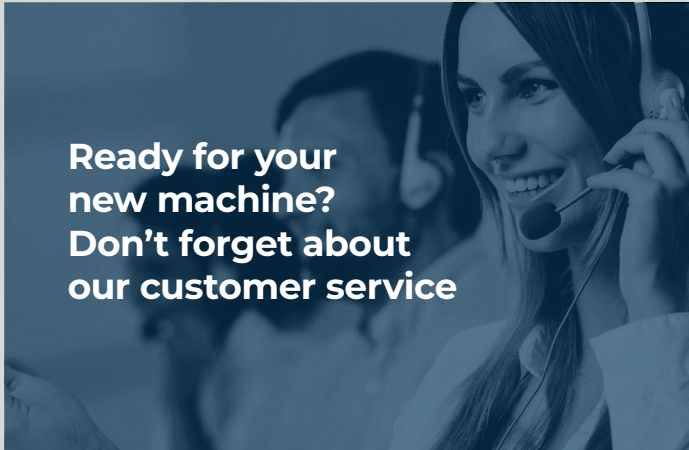

**Ready for your  
new machine?  
Don't forget about  
our customer service**

### **On Field Assistance**

We provide complete life-cycle support services and printing processes to ensure maximum performance throughout the entire lifespan of the machine.

### **Remote Assistance**

Thanks to the newest technologies available on the market we guarantee the best real-time support.

### **Upgrades Service**

We provide improvements of the efficiency and performances of your machine's processes, aligning them to the latest technological market trends.

### **Spare Parts**

We have a series of spare parts checked and guaranteed by us.

### **Equipment**

We offer equipment solutions to be added to your specific machine to boost its performance and efficiency.







**JOIN THE FLEX-CONVERTING**





---

**Uteco Converting SpA**  
Viale del Lavoro, 25  
37030 Colognola ai Colli (VR)  
Ph: +39 045 6174555  
[utecovr@uteco.com](mailto:utecovr@uteco.com)  
[www.uteco.com](http://www.uteco.com)



Data, features and photos shown are not binding.  
Uteco Group reserves the right to make any changes without prior notice.