

PRISMA CLG

OUR NEW COATING AND
LAMINATING PRODUCT RANGE



PrismaCLG Product Family – Overview

Our Coating & Laminating product range.

PRISMA FAMILY

PRISMA^{CG}

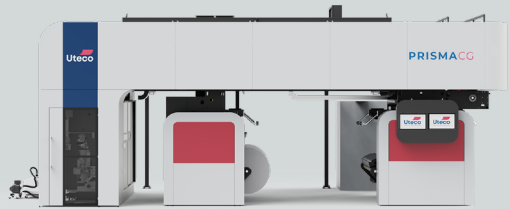

PRISMA^{LG}



PRISMA^{CLG}

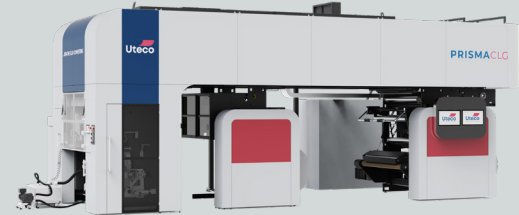

PrismaCLG - Overview

Our Coating & Laminating machines.



TECHNICAL SPECIFICATION

PRISMACG

PRISMALG

PRISMACLG

C&L TYPE

COATING
(SOLVENT & WATER
BASED)

LAMINATING
(SOLVENTLESS)

LAMINATING
(SOLVENT & WATER
BASED & SOLVENTLESS)

LAMINATING UNIT

NO

YES

YES

TROLLEYS

MULTI-PURPOSE
TROLLEYS

SOLVENTLESS FIXED
UNIT

MULTI-PURPOSE
TROLLEYS



PrismaCLG - Overview

Process Description for "C&L" type.

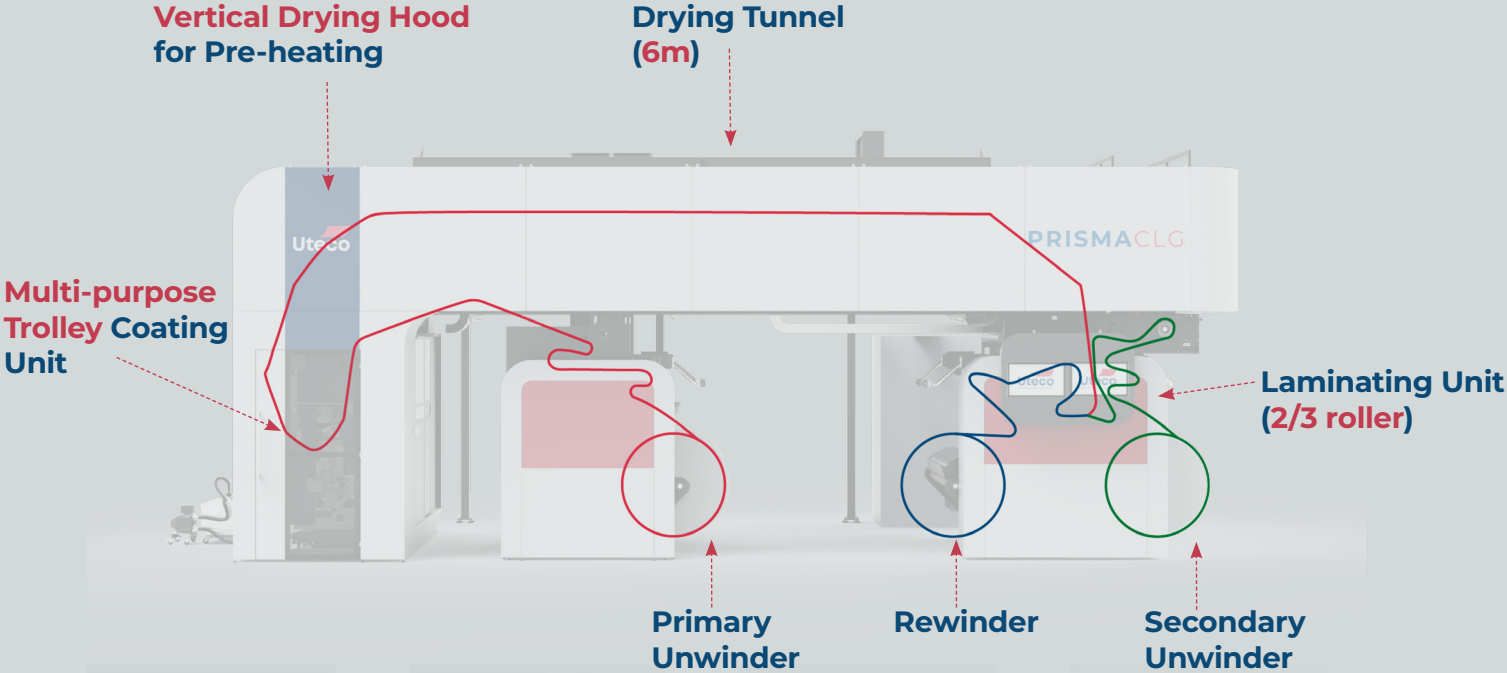

PrismaCG - Overview

Process Description for "Coater" type.

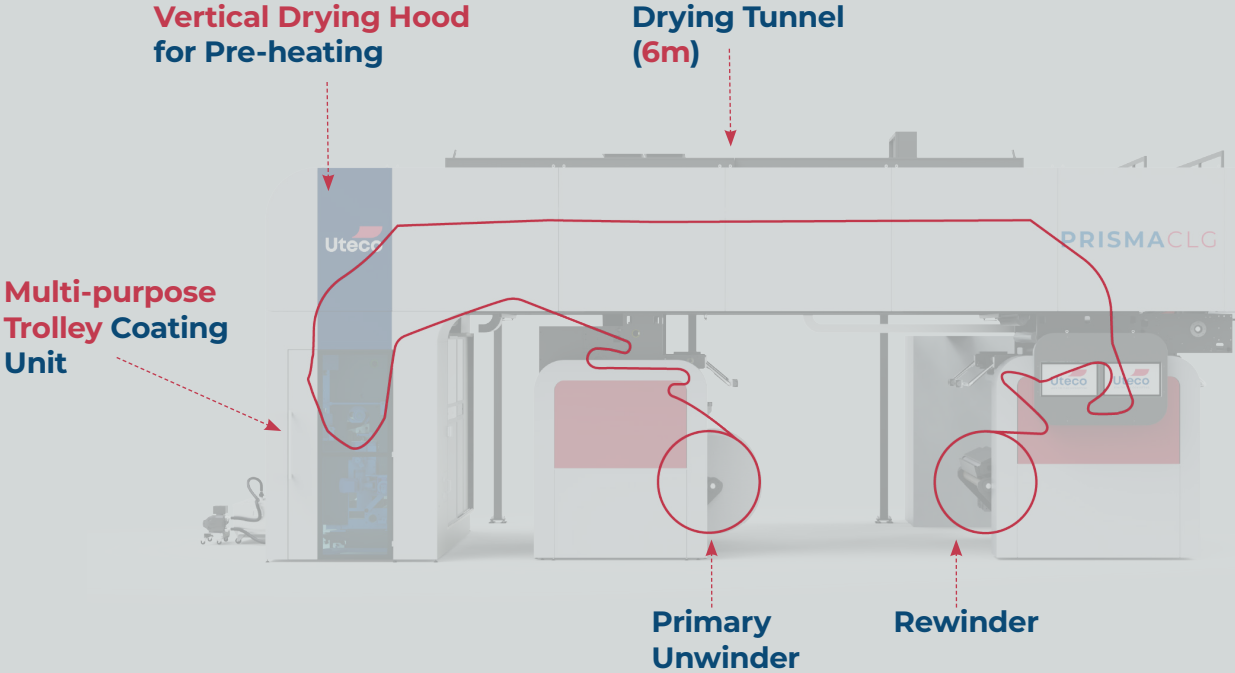

PrismaLG - Overview

Process Description for "Laminating" type.

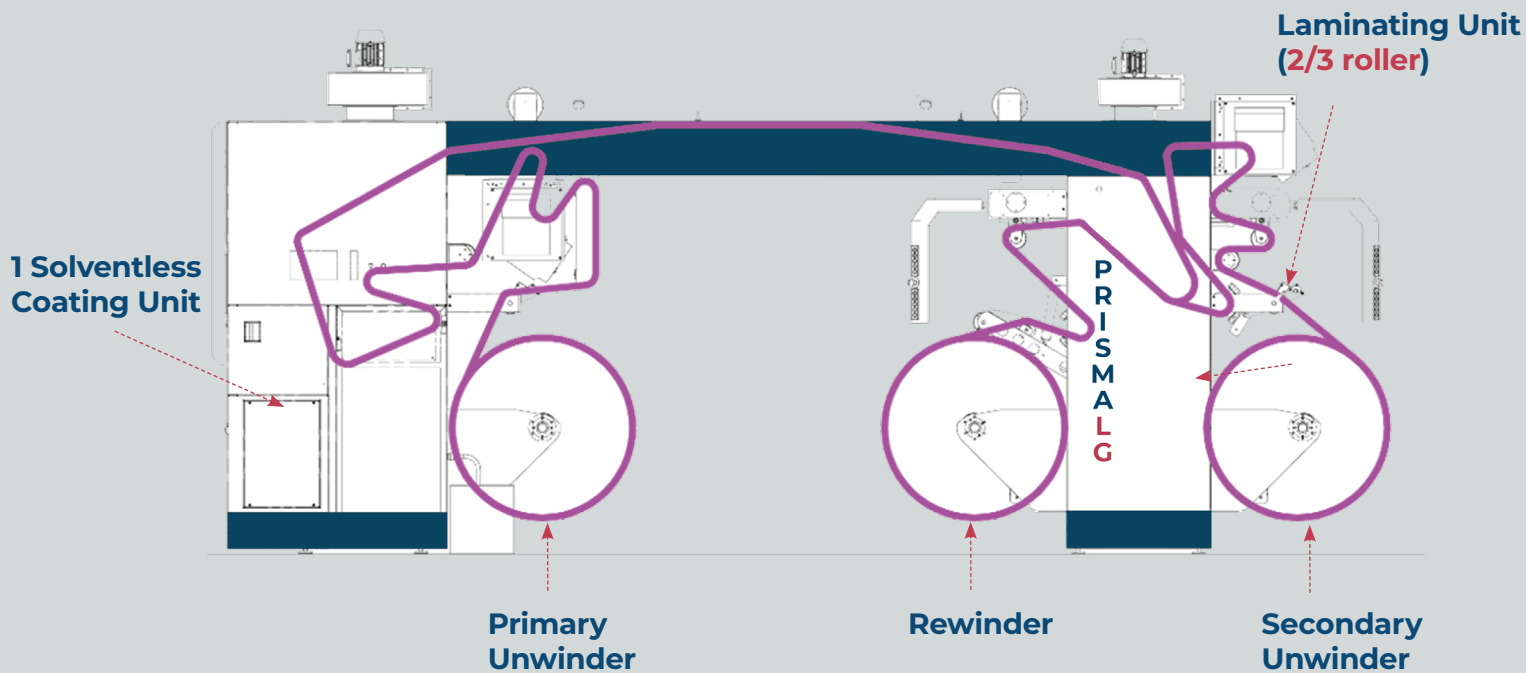

PrismaCLG - Value Proposition

PRISMACLG &
PRISMACG
Value Proposition

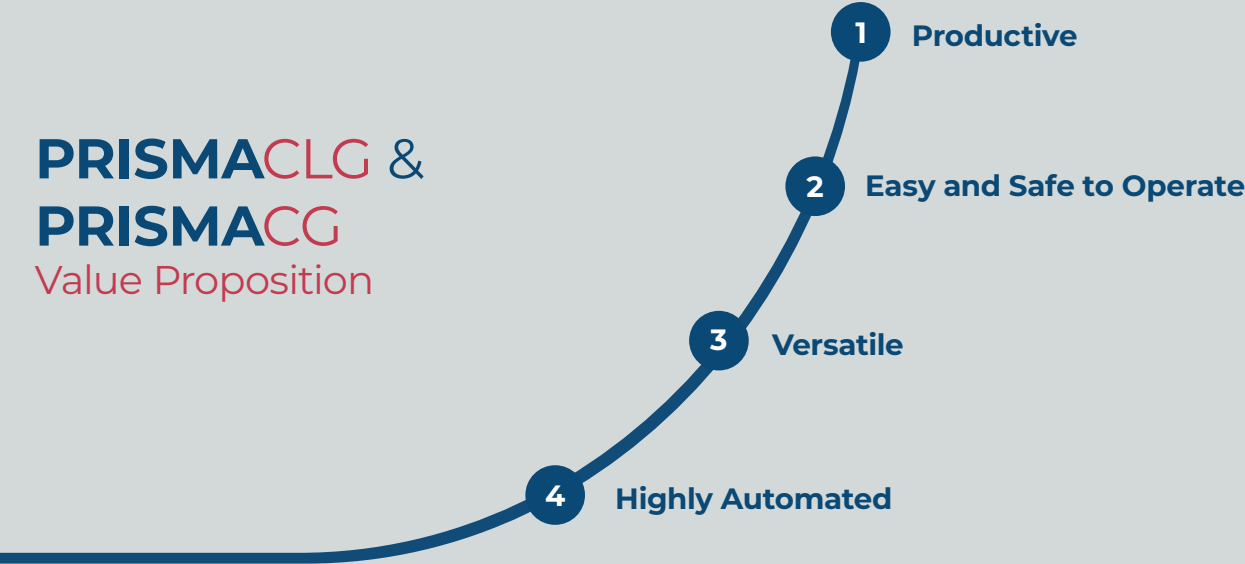

1. Productive – Fast Job Changeover

2 Web Threads to separate Solventless and Solvent-based laminating passage **reducing changeover time.**

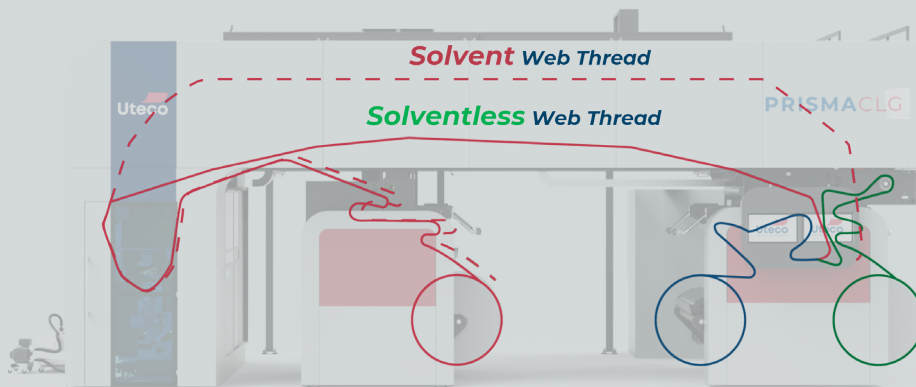

- 1** Complete Changeover from **Solventless** to **Solvent-based** in **<10min**
- 2** **3x Faster** changeover than any other Solution in the Market
- 3** Down to **30m** Material Waste

1. Productive – Drying Boost

Enhanced drying capabilities for high speed.

ENHANCED & CONTROL DRYING FOR HIGHER SPEEDS

A vertical **pre-heating hood** installed **above the coating module**, upstream of the tunnel, **extending the drying area by about 1m.**

Pre-heat the substrate and make the system **more efficient for applications that require more drying.**

UP TO 20% INCREASE IN DRYING CAPACITY (*)

(*) Vs Standard Solutions

Drying Boost with Vertical Hood

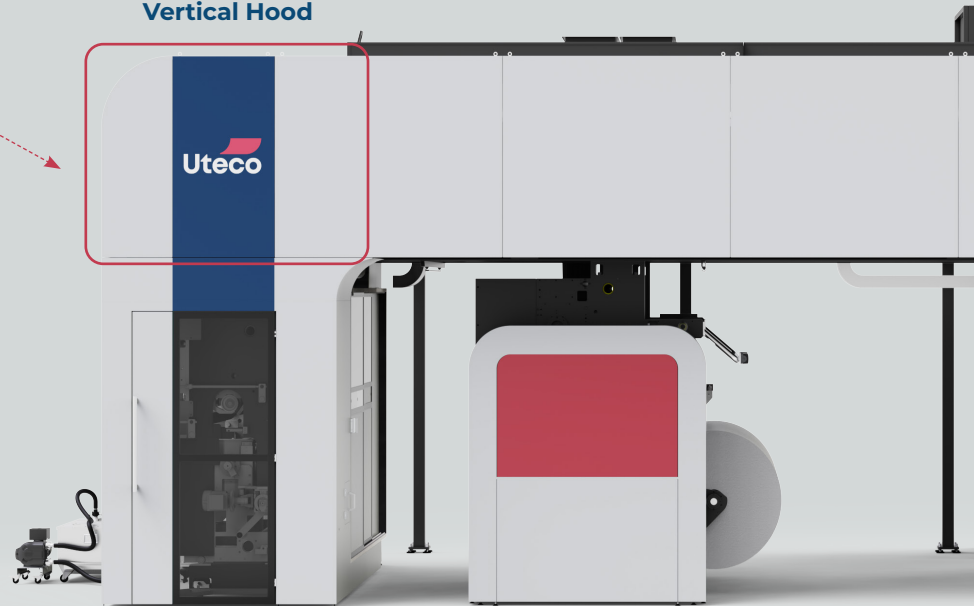

1. Productive – Efficient Drying Tunnel

Enhanced drying capabilities for high speed.

6 METERS DRYING TUNNEL

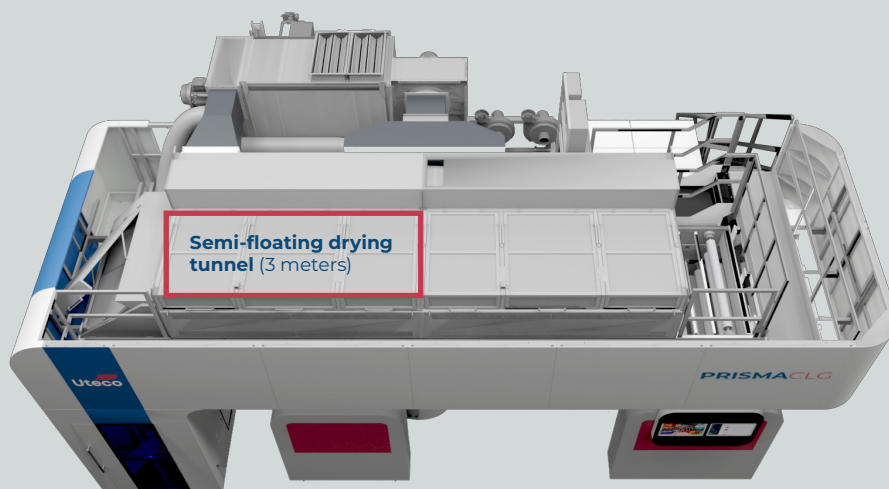

- ✓ Equipped with Uteco **“semi-floating” technology** in the **first 3 meters of the tunnel**
- ✓ Motorized Rollers for the **greatest material handling precision**
- ✓ Perfect tensioning of very **stretchable materials** and **special materials** like alu-foil or metallized films

2. Easy & Safe to Operate - Accessible Catwalk

Easy to access catwalk.

Maximum accessibility for **cleaning, inspection** and **maintenance operations** to be performed in **complete safety and ergonomics**.

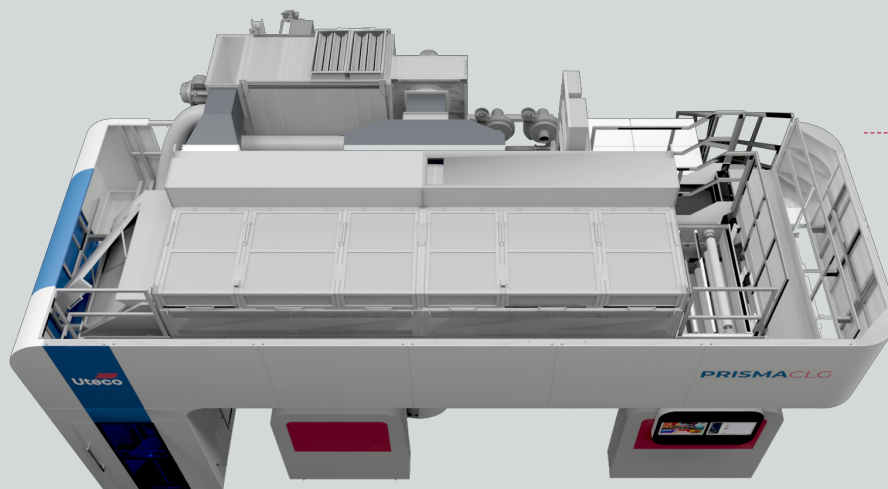

Fully
Accessible
Catwalk



2. Easy & Safe to Operate - New suction System for VOC Control

Guarantee 100% Solvent free environment.



**Solvent Free
Environment**
(thanks to new
suction system)



2. Easy & Safe to Operate - Inspection System

Our Innovative Inspection System.

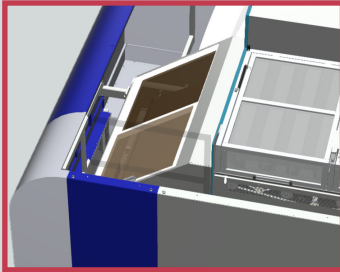

Ensure cleanliness and safety with our Advanced Inspection System

Substrates dirt-free while minimizing accidents and defects.

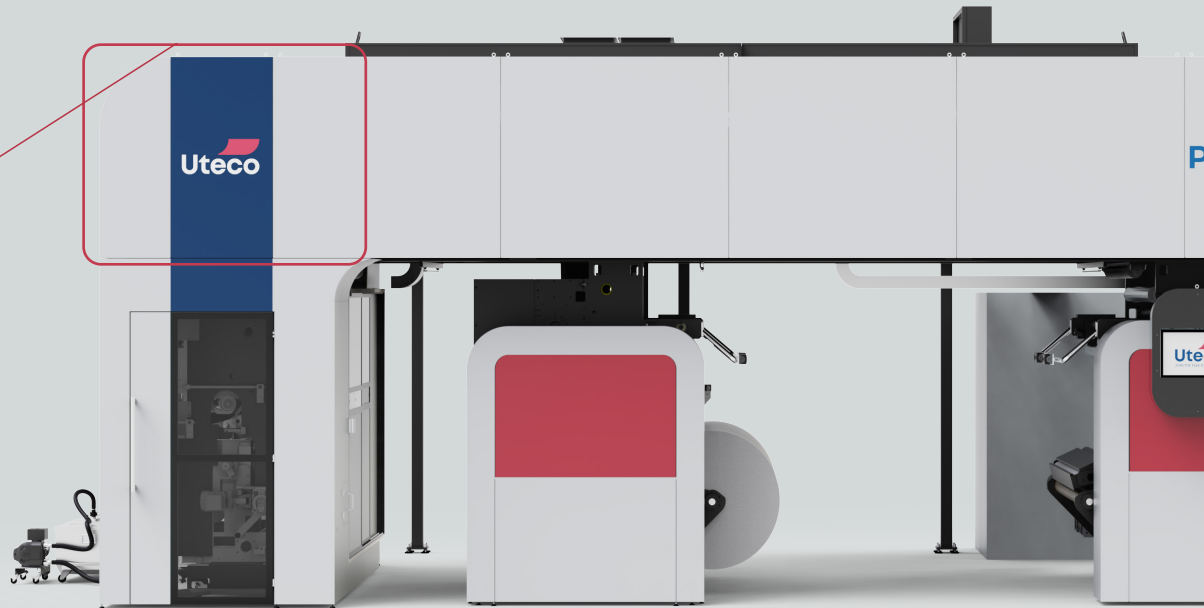

3. Versatile – Multi-Purpose Coating Trolley

Multi Purpose Coating Trolley.

Our Multi Purpose Coating Trolley

Roto/Flexo/Semi-flexo

Solventless

Equipped with Automatic
Washing System 

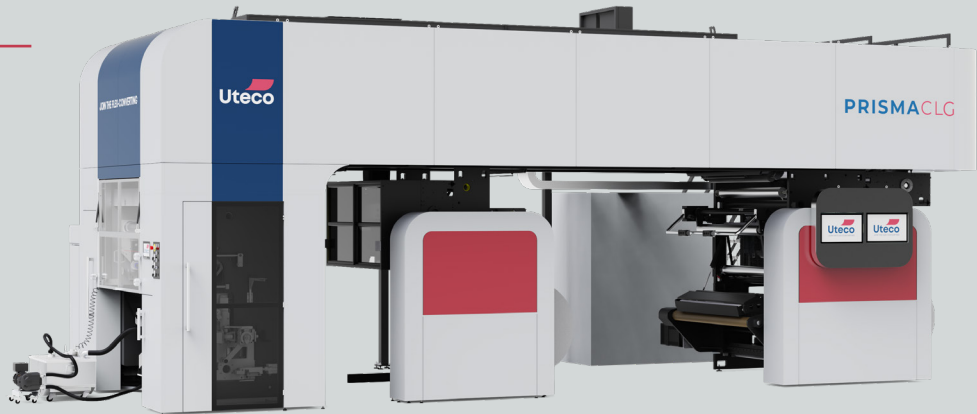

3. Versatile – The Widest Laminating Possibilities

Explore the widest laminating possibilities.



MULTI-INDUSTRY

Food (including pet food), Beverages, Pharmaceuticals, Healthcare, Personal Care, Home and Office, Industrial



MULTILAYER



MULTI-MATERIAL

Plastic Film, Aluminum, Paper, Cardboard



PAPER



CARDBOARD



MULTI-ADHESIVES

Solvent-Based, Water-Based (Cold Seal), Solventless



PLASTIC FILM



ALUMINIUM



4. Highly Automated – Dynamic Tension

Fully Automatic Regulation of Material Tensioning.



Automatic Regulation of Material Tensioning

Set the **Perfect Material Tensioning** without Operator Intervention for **Faster Setup Times** and **Safer Operations**

6x Faster Automatic System for Substrate Tension Regulation(*)

(*) Vs Manual Operations

PrismaCLG - Overview

Footprint & Dimensions.

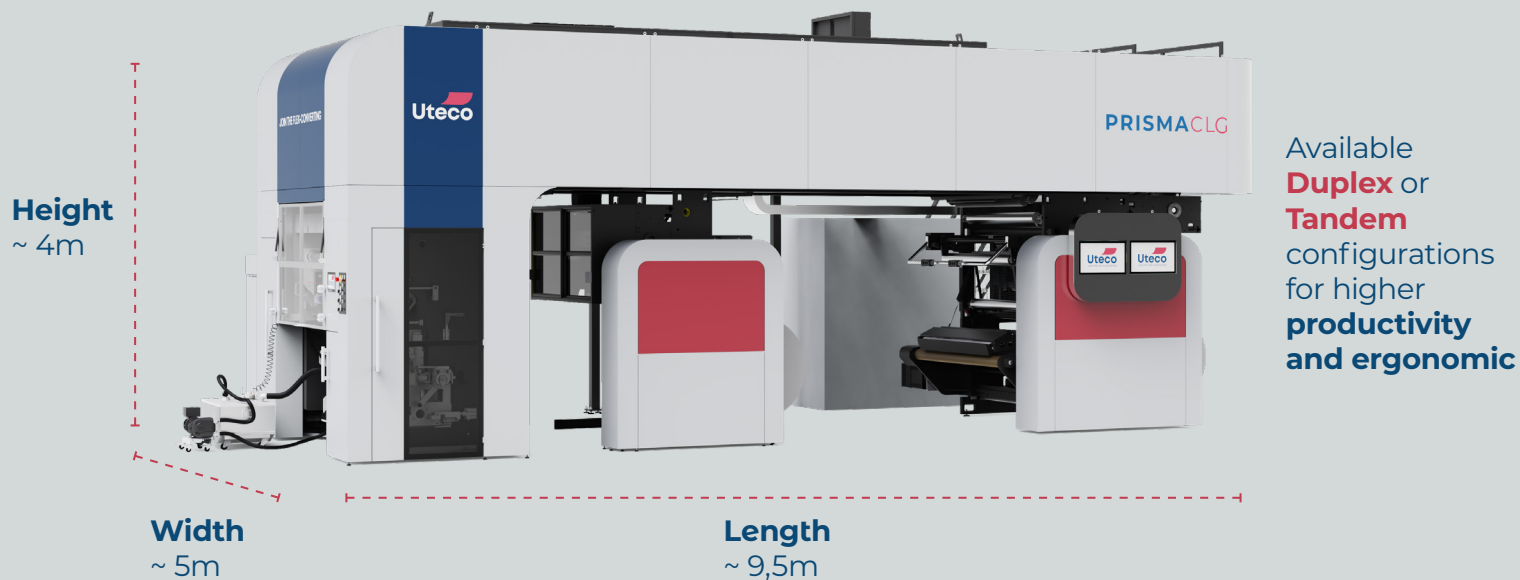

PrismaCLG & PrismaCG - Technical Specifications

Parameter	Unit of Measurement	Value
Min/Max Material Width	[mm]	1050 ÷ 1550
Min/Max coating width	[mm]	1030 ÷ 1530
Max coating speed	[mpm]	450
Unwin./rewin. max diameter	[mm]	1000
Film Tension Unwinder	[Kg]	3 ÷ 40
Film Tension Rewinder	[Kg]	4 - 50
Max Reel Weight	[Kg]	1500

PrismaLG - Overview

PRISMA^{LG}

The perfect machine for
solventless lamination



PrismaLG – Laminator Key Features

Solventless Transfer Roll for automatic sleeve change.



The **rubber transfer roller** is sleeve type and shaped according to the coating width.

It guarantees the **coating of very smooth layer of adhesive**. Easy changeover thanks to the sleeved roll.

PrismaLG – Laminator Key Features

Roller Laminating Nip for run even most stretchable materials.

The three-roller Laminating Nip allows for accurate control of the laminating avoiding visual defects such as bubbling or curling, even with the most stretchable films.

Moreover, **web tension is constantly controlled on all zones via highly sensitive dancing rollers and vectorial motors.**

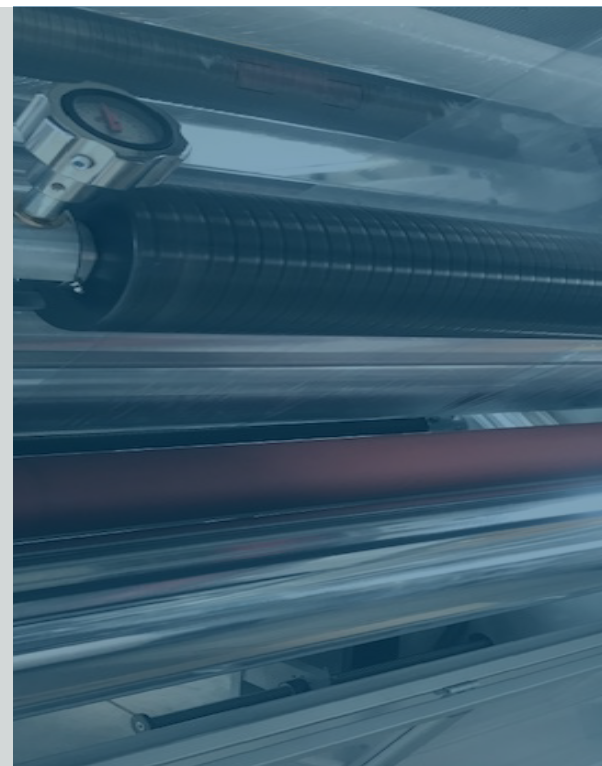

PrismaLG – Laminator Key Features

Automatic Washing System for quicker changeovers.

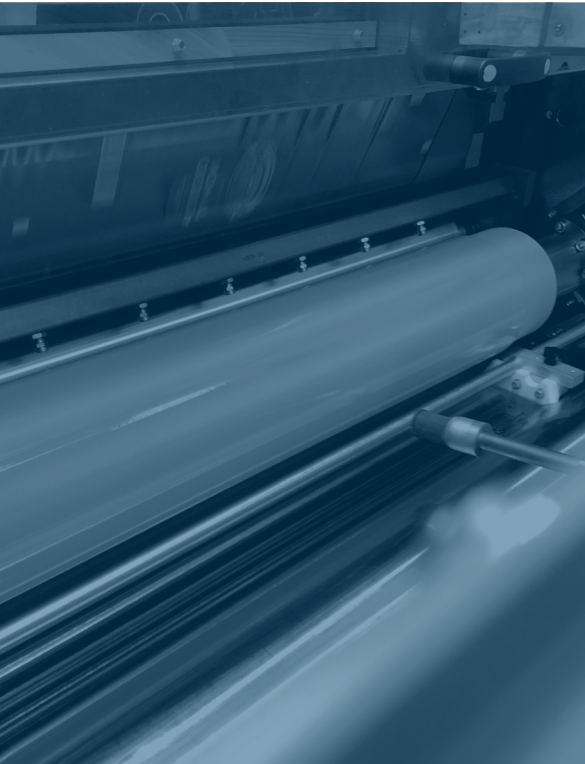

■ The coating unit is equipped as standard with an **automatic washing system for all rollers.**

It optimizes the **changeover time and allows significant saving of solvent during washing operations.**

PrismaLG – Laminator Key Features

Fully Automatic Unwinders and Rewinders (Only PrismaLR) to boost productivity.

■ **Fully Automatic reels change** thanks to the flying splice unwinders and rewinders.

Reels changing does not require machine downtime and production can continue unceasingly.

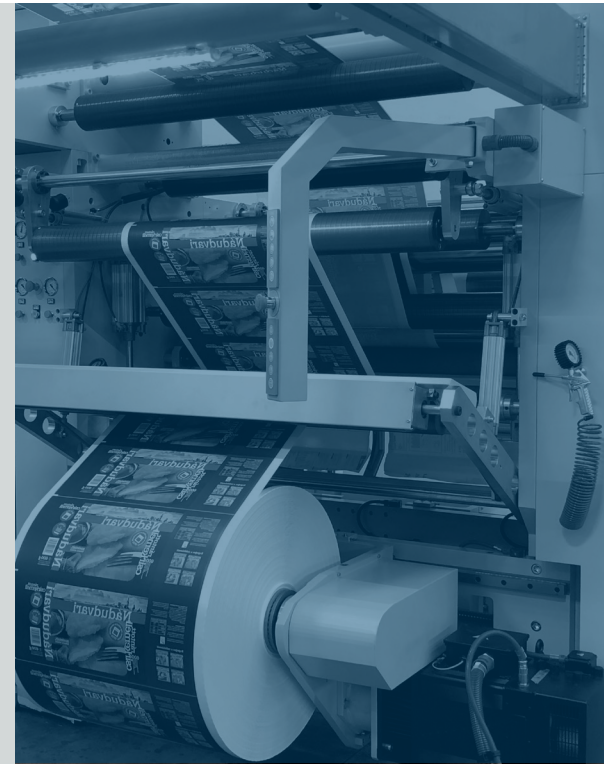

PrismaLG - Overview

Footprint & Dimensions.



PrismaLG - Technical Specifications

Parameter	Unit of Measurement	Value
Min/Max Material Width	[mm]	1050 ÷ 1350
Min/Max coating width	[mm]	1030 ÷ 1330
Max coating speed	[mpm]	500
Unwin./rewin. max diameter	[mm]	1000
Film Tension Unwinder	[daN]	2 ÷ 50
Max Reel Weight	[Kg]	1500



Our Company

Printing and Converting: All Round **High Tech Innovation.**



We provide innovative and flexible solutions from a wide range of **flexographic, rotogravure, digital printing, laminating and coating machines** and a corollary of comprehensive training and support services.

We develop **special and customized configurations** of high technological value, with an ongoing commitment to research and **innovation, organizational flexibility, engineering capabilities for final solutions**, optimization of production processes, and a fast and efficient worldwide service network.

Our Customer Service

Our Customer Service has **Everything You Need.**

Our expert **Customer Service teams** are **available 24/7** to respond quickly and effectively to requests for maintenance, repairs and operational renovations to machinery and systems, **both on-site and remotely (My Portal).**

Ready for your
new machine?
Don't forget about
our customer service



Find out more!

On Field Assistance

We provide complete **life-cycle support services and printing processes** to ensure maximum performance throughout the entire lifespan of the machine.

Remote Assistance

Thanks to the newest technologies available on the market we guarantee **the best real-time support.**

Upgrades Service

We provide improvements of the efficiency and performances of your machine's processes, aligning them to the **latest technological market trends.**

Spare Parts

We have a series of spare parts checked and guaranteed by us.

Equipment

We offer equipment solutions to be added to your specific machine to **boost its performance and efficiency.**





Release date April 2026

Uteco Converting SpA

Viale del Lavoro, 25
37030 Colognola ai Colli (VR)
Ph: +39 045 6174555
utecovr@uteco.com
www.uteco.com



Data, features and photos shown are not binding.
Uteco Group reserves the right to make any changes without prior notice.